

ELEVATION
DOUBLE SWING GATE (TYPE FE-5 FENCE)

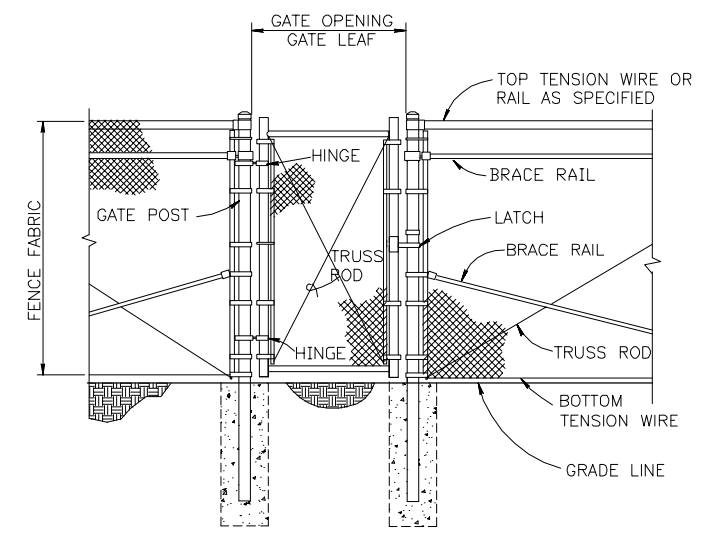

PERSONNEL GATE
TYPE FE-5 FENCE

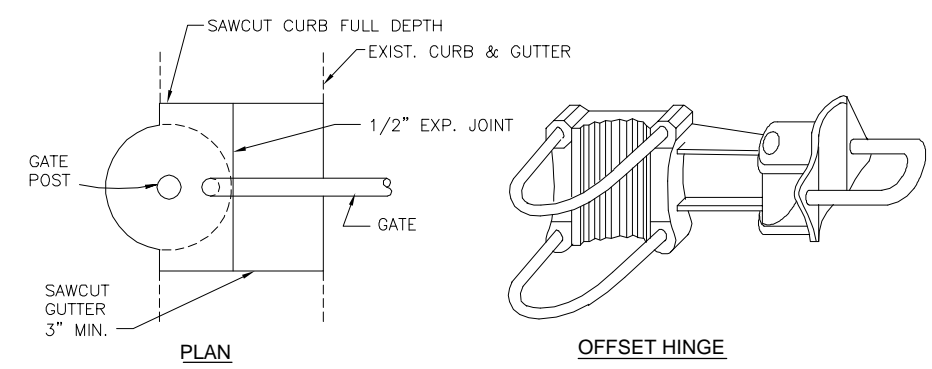

PLAN

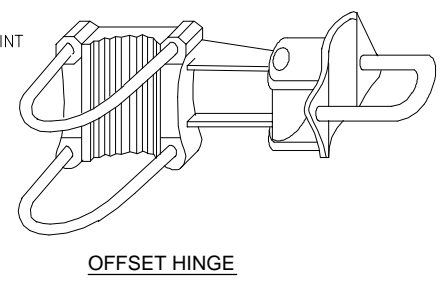

OFFSET HINGE

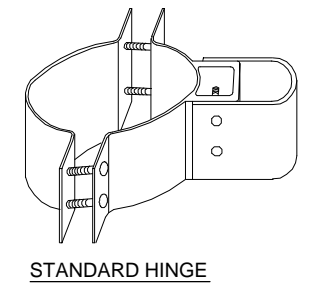

STANDARD HINGE

GATE POST SCHEDULE	
GATE LEAF WIDTH (NOMINAL)	OUTSIDE DIMENSION (NOMINAL)
6' OR LESS	2.875" OD 2.5" SQ
6' TO 13'	4.0" OD
13' TO 18'	6.625" OD
MORE THAN 18'	8.625" OD

NOTES:

1. DETAILS SHOWN ARE TO CLARIFY REQUIREMENTS AND ARE NOT INTENDED TO LIMIT OTHER TYPE OF FENCE SECTIONS AND METHODS OF INSTALLATION.
2. SWING GATES SHALL BE CONSTRUCTED WITH DROP RODS, PADLOCKS, LATCH ASSEMBLY AND GATE KEEPERS EXCEPT AS NOTED.
3. ALL GATE FRAMES SHALL BE A MINIMUM 1.90" NOMINAL (ROUND) OR 2.00" NOMINAL (SQUARE). GATE FRAMES SHALL BE OF WELDED CONSTRUCTION OR SHALL BE ASSEMBLED USING HEAVY FITTINGS. AT CONTRACTOR'S OPTION A WELDED HORIZONTAL BRACE MAY BE USED IN LIEU OF TRUSS RODS TO BRACE ALL WELDED GATE FRAMES. THE CONTRACTOR SHALL BE RESPONSIBLE FOR THE PROPER RIGID CONSTRUCTION OF ALL GATES SUPPLIED.
4. GATES SHALL BE DESIGNATED AS FOLLOWS:
 FENCE TYPE - FE5, FE6, ETC.
 FENCE HEIGHT - INCHES
 TYPE OPENING - SO (SINGLE), DO (DOUBLE), RA (STANDARD), HO (OFFSET)
 OPENING - FEET (CLEAR OPENING BETWEEN GATE POSTS)
 EXAMPLES: - FE6-84-DO-RA-24, FE5-48-SO-HO-6

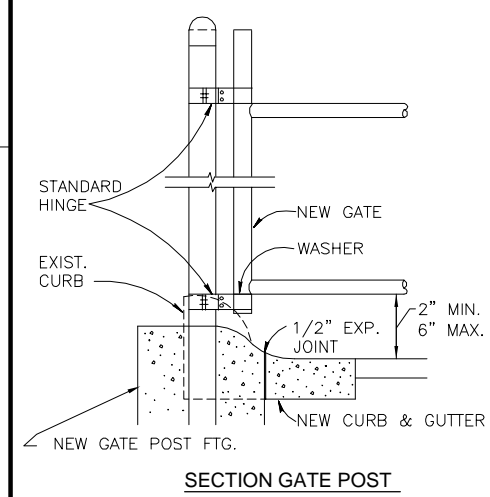

SECTION GATE POST

DETAIL AT CURB AND GUTTER
ND SCALE

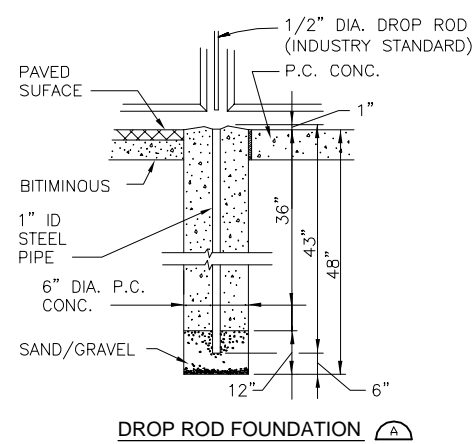

DROP ROD FOUNDATION

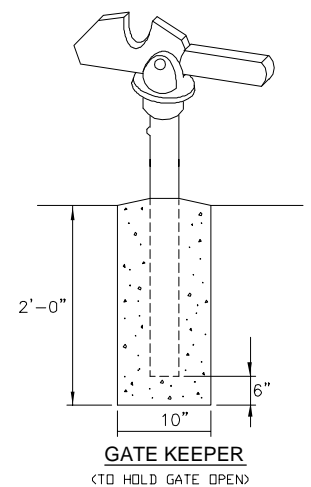

GATE KEEPER

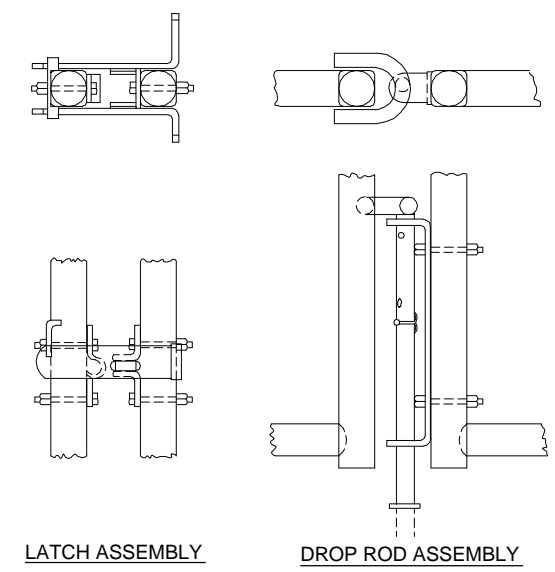

LATCH ASSEMBLY
DROP ROD ASSEMBLY
SWING GATE DETAILS
ND SCALE

\$\$ - THINK VALUE ENGINEERING - \$\$

Revisions			
Symbol	Descriptions	Date	Approved

U.S. ARMY ENGINEER DISTRICT
CORPS OF ENGINEERS
OMAHA, NEBRASKA

Designed by: X	X
Drawn by: X	
Checked by: X	
Reviewed by:	
Submitted by:	
Chief: X	Section

STANDARD DETAILS FOR CHAIN-LINK SECURITY FENCES AND FARM STYLE FENCES

FE5 CHAIN-LINK SECURITY FENCE GATE DETAILS

Plot Scale Ratio: 10/01	Date: 10/01	Sheet reference number: 07
Design File: FESGATE.DGN	Drawing Code: STD 872-90-07	
Spec. No.: DACA 45		
Contract No.: DACA 45		